

SCM7B47

Isolated Linearized Thermocouple Input Modules



Description

SCM7B47 modules accept a single channel of input from Type J, K, T, E, R, S, B, or N thermocouples. The signal is filtered, isolated, amplified, linearized, and converted to a high-level analog voltage for output to the process control system (Figure 1).

Linearization is achieved by creating a non-linear transfer function through the module itself; refer to AN505. This non-linear transfer function is configured at the factory and is designed to be equal and opposite to the thermocouple non-linearity.

Cold junction compensation (CJC) is performed using an NTC thermistor (see "Additional SCM7B Part Numbers" section for P/N and AN701 for further information) externally mounted under the field-side terminal block on the backpanel (Figure 1). Open thermocouple detection is upscale using a 30nA current source in the input circuitry.

These modules incorporate a five-pole filtering approach to maximize both time and frequency response by taking advantage of both Thomson (Bessel) and Butterworth characteristics. One pole of the filter is on the field side of the isolation barrier; four are on the process control system side.

After the initial field-side filtering, the input signal is chopped by a proprietary chopper circuit and transferred across the transformer isolation barrier, suppressing transmission of common mode spikes and surges. The signal is then reconstructed and filtered for process control system output.

Modules accept a wide 14 - 35VDC power supply range (+24VDC nominal). Their compact packages (2.13"x1.705"x0.605" max) save space and are ideal for high channel density applications. They are designed for easy DIN rail mounting using any of the "-DIN" backpanels.

► Features

- Interfaces to Type J, K, T, E, R, S, B and N Thermocouples
- Linearizes Thermocouple Signals
- Provides High-Level Voltage Outputs
- 1500Vrms Transformer Isolation
- Accuracy, ±0.06% to ±0.16% of Span Typical
- ANSI/IEEE C37.90.1 Transient Protection
- Input Protected to 120Vrms Continuous
- Noise, 1mVp-p (5MHz), 500µVrms (100kHz)
- 160dB CMRR
- 85dB NMR at 60Hz, 80dB at 50Hz
- Easy DIN Rail Mounting
- CSA C/US Certified
- CE and ATEX Compliant

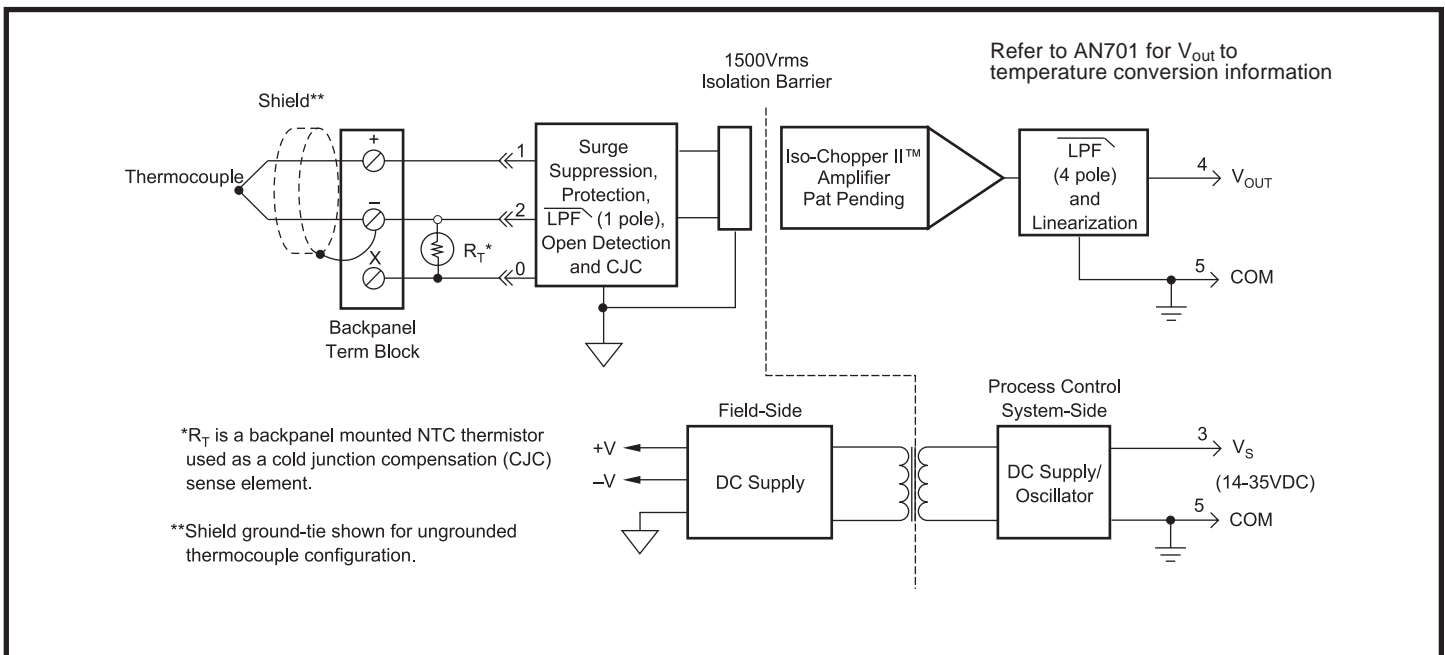

Figure 1: SCM7B47 Block Diagram

Specifications Typical* at 25°C and +24VDC

| Module | SCM7B47 |
|---|---|
| Input | |
| Signal Range | Thermocouple ⁽¹⁾ (See Ordering Information) |
| Current | -30nA |
| Resistance | |
| Normal | 50MΩ |
| Power Off | 30kΩ min |
| Overload | 30kΩ min |
| Protection | |
| Continuous | 120Vrms max |
| Transient | ANSI/IEEE C37.90.1 |
| Output | |
| Signal Range ⁽²⁾ | † |
| Effective Available Power ⁽²⁾ | 40mW |
| Resistance | <1Ω |
| Protection | Continuous Short-to-Ground |
| Voltage/Current Limit | ±12V, ±14mA |
| CMV (Input-to-Output) | |
| Continuous | 1500Vrms |
| Transient | ANSI/IEEE C37.90.1 |
| CMRR (50 or 60Hz) | 160dB |
| Accuracy⁽³⁾ | (See Ordering Information) |
| Stability (-40°C to +85°C) | |
| Gain | ±40ppm/°C |
| Input Offset | ±0.5μV/°C |
| Zero Suppression | ±0.005%(V _z) ⁽⁴⁾ /°C |
| Output Offset | ±0.002% Span/°C |
| Noise | |
| Peak at 5MHz B/W | 1mV |
| RMS at 10Hz to 100kHz B/W | 500μV |
| Peak at 0.1Hz to 10Hz B/W | 1μV RTI |
| CJC Accuracy ⁽⁵⁾ | ±0.25°C Typ, ±1°C max |
| +5°C to +45°C ambient | |
| Open Input Response | Upscale |
| Open Input Detection Time | <10s |
| Frequency and Time Response | |
| Bandwidth, -3dB | 3Hz |
| NMR (50/60Hz) | 80/85dB |
| Step Response, 90% Span | 165ms |
| Supply Voltage | |
| Current ⁽²⁾ | 14 to 35VDC |
| Sensitivity | 16mA |
| | ±0.0001%/V _s |
| Mechanical Dimensions (h)(w)(d) | 2.13" x 1.705" x 0.605" max 54.1mm x 43.3mm x 15.4mm max |
| Environmental | |
| Operating Temperature Range | -40°C to +85°C |
| Storage Temperature Range | -40°C to +85°C |
| Relative Humidity | 0 to 95% Noncondensing |
| Emissions EN61000-6-4 | ISM, Group 1 |
| Radiated, Conducted | Class A |
| Immunity EN61000-6-2 | ISM, Group 1 |
| RF | Performance A ±0.5% Span Error |
| ESD, EFT | Performance B |

NOTES:

* Contact factory or your local Dataforth sales office for maximum values.

(1) Thermocouple characteristics per NIST monograph 175, ITS-90.

 (2) Output Range and Supply Current specifications are based on minimum output load resistance. Minimum output load resistance is calculated by V_{out}^2/P_E , where P_E is the output Effective Available Power that guarantees output range, accuracy, and linearity specifications.

(3) Accuracy includes the effects of repeatability, hysteresis, and conformity.

 (4) V_z is the nominal input voltage that results in a 0V output.

(5) The CJC sensor accuracy should be added to the module accuracy and thermocouple accuracy to compute overall measurement accuracy.

Ordering Information

| Model† | Input Range | Accuracy ⁽³⁾⁽⁵⁾ | |
|-------------|---|----------------------------|-------------------------|
| | | Typical | Max |
| SCM7B47J-01 | 0°C to +760°C (+32°F to +1400°F) | ±0.11% Span (0.84°C) | ±0.32% Span (3.43°C) |
| SCM7B47J-02 | -100°C to +300°C (-148°F to +572°F) | ±0.10% Span (0.40°C) | ±0.30% Span (1.20°C) |
| SCM7B47K-03 | 0°C to +1300°C (+32°F to +2372°F) | ±0.11% Span (1.43°C) | ±0.32% Span (4.16°C) |
| SCM7B47K-04 | 0°C to +600°C (+32°F to +1112°F) | ±0.06% Span (0.36°C) | ±0.18% Span (1.08°C) |
| SCM7B47T-05 | 0°C to +400°C (+32°F to +752°F) | ±0.13% Span (0.52°C) | ±0.38% Span (1.52°C) |
| SCM7B47T-06 | -100°C to +200°C (-148°F to +392°F) | ±0.16% Span (0.48°C) | ±0.47% Span (1.41°C) |
| SCM7B47E-07 | 0°C to +900°C (+32°F to +1652°F) | ±0.11% Span (0.99°C) | ±0.34% Span (3.06°C) |
| SCM7B47R-08 | +500°C to +1750°C (+932°F to +3182°F) | ±0.10% Span (1.25°C) | ±0.30% Span (3.75°C) |
| SCM7B47S-09 | +700°C to +1750°C (+1292°F to +3182°F) | ±0.08% Span (0.84°C) | ±0.25% Span (2.63°C) |
| SCM7B47B-10 | +800°C to +1800°C (+1472°F to +3272°F) | ±0.12% Span (1.20°C) | ±0.35% Span (3.50°C) |
| SCM7B47N-11 | +200°C to +1300°C (+392°F to +2372°F) | ±0.09% Span (0.99°C) | ±0.27% Span (2.97°C) |

SCM7B

†Output Ranges Available

| Output Range | Part No. Suffix | Example |
|--------------|-----------------|--------------|
| +1 to +5V | NONE | SCM7B47J-01 |
| 0 to +5V | A | SCM7B47J-01A |
| 0 to +10V | D | SCM7B47J-01D |

†Thermocouple Alloy Combinations

Standards: DIN IEC 584, ANSI MC96-1-82, JIS C 1602-1981

| Type | Material |
|------|--|
| J | Iron vs. Copper-Nickel |
| K | Nickel-Chromium vs. Nickel-Aluminum |
| T | Copper vs. Copper-Nickel |
| E | Nickel-Chromium vs. Copper-Nickel |
| R | Platinum-13% Rhodium vs. Platinum |
| S | Platinum-10% Rhodium vs. Platinum |
| B | Platinum-30% Rhodium vs. Platinum-6% Rhodium |
| N | Nickel-14.2% Chromium-1.4% Silicon vs. Nickel-4.4% Silicon- 0.1% Magnesium |